



*open  
for life*

## **KD DOOR FRAME**



2018

[www.vrata-derzic.si](http://www.vrata-derzic.si)





***Our door - your pleasure - our pride.  
For 20 years ...***



## Content:

KD DOOR FRAME DESCRIPTION .....	3
SLOVENIAN TECHNICAL APPROVALS AND CERTIFICATES.....	4
DETERMINING OPENING DIRECTION .....	5
DOOR FRAME FORMATS .....	6
DETERMINING DIMENSIONS .....	8
DOOR FRAME TYPES.....	11
KD.MM.....	12
Basic model – 1 0 .....	13
Basic model – 1 1 .....	13
KD.SM .....	14
KD.SM door frame specific features.....	15
Basic model – 1 0 .....	16
Basic model – 1 1 .....	16
Model with hidden bolts – 2 0.....	17
Model with hidden bolts – 2 1 .....	17
Non-rebated model – 3 0 .....	18
Non-rebated model – 3 1 .....	18
Corner model – 4 0.....	19
Corner model – 4 1 .....	19
Extension of drywall door frames – 5 0 .....	20
KD.KN .....	21
KD.KN door frame specific features.....	22
Basic model – 1 0 .....	23
Basic model – 1 1 .....	23
Model with hidden bolts – 2 0.....	24
Model with hidden bolts – 2 1 .....	24
Non-rebated model – 3 0 .....	25
Non-rebated model – 3 1 .....	25
KD.SR .....	26
Basic model – 1 0 .....	27
Basic model – 1 1 .....	27

KD.OR.....	28
Basic model – 1 0 .....	29
BASIC model – 1 1 .....	29
TRANSOMS FOR FANLIGHTS AND SIDELIGHTS .....	30
DOOR FRAME EQUIPMENT.....	32
HINGES .....	32
HEIGHT OF HINGES .....	32
SUBCONSTRUCTIONS FOR HINGES.....	33
STRIKING PLATES.....	36
HEIGHT OF STRIKING PLATES.....	36
CUT-OUT SECTIONS FOR STRIKING PLATES .....	37
HOLES FOR BOLTING.....	38
SPECIAL DOOR FRAMES .....	39
ORDERING INSTRUCTIONS .....	42



## KD DOOR FRAME DESCRIPTION

Metal KD door frames are manufactured from cold rolled electrogalvanised sheet metal with SIST EN 10152 quality and the designation DC01 EZ25/25 A-PC.

In most cases KD door frames consist of two parts – the basic and stop profile. Other essential parts of the door frame are:

- forend,
- rebate,
- groove for sealing rubber.

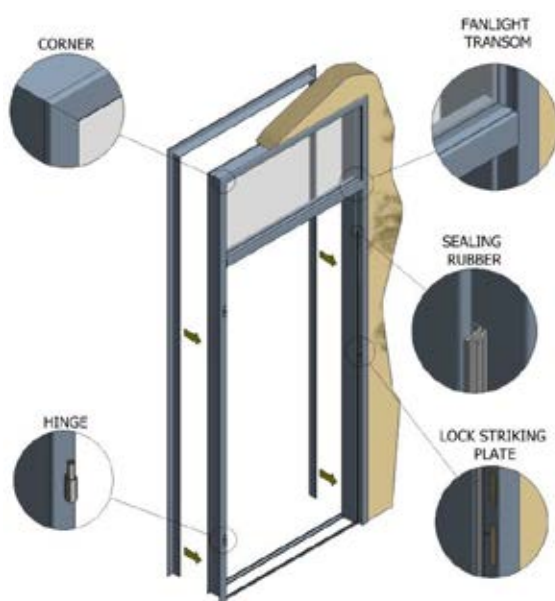
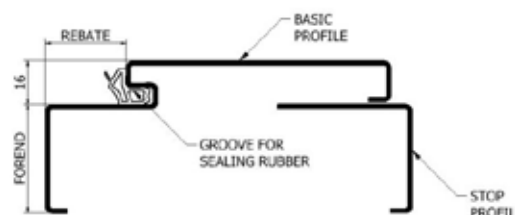

Door frame equipment:

- door frame hinge,
- sealing rubber,
- lock striking plate.

A door hinge can be supplied on the basis of an individual agreement. Based on your order, different subconstructions can be fitted to KD door frames so that the final product is suitable for your choice of hinges, lock striking plates, additional bolting, and wedges for two-part door frames.

In the case of fanlight KD door frames, the door frame corners and joints for the transom are welded. All welds are treated in such a way that

they cannot be detected and the final product is smooth. Metal KD door frames are not load-bearing elements.

KD door frames are suitable for rebated leaves, in which case they have a rebate depth of 30 mm, or for non-rebated leaves, in which case they have a rebate depth of 48 mm.

KD door frames are suitable for buildings that are the result of rapid construction, modern construction techniques, and special requirements. They are installed in apartments, hospitals, schools, nursery schools, shopping centres, industrial and business premises, tourist facilities, etc.

We offer many types of standard KD door frames. Based on your requirements, we also manufacture special profiles that are designed in the Autodesk Inventor 3D program before they are realised.

The surface of KD door frames is protected by a layer of powder coating in accordance with DIN 55633 and EN ISO 12944. A standard application of the coating achieves C2 category protection. A C3 category is recommended for KD door frames that are partly exposed to external conditions, which should be specified when ordering.

The basic colours of the coating are selected from the RAL colour chart, but in the case of larger orders it is possible to arrange for special colours according to your wishes.



KD door frames can also be manufactured from stainless sheet metal. Such door frames are suitable for rooms with specific requirements, e.g. where various chemicals are used for cleaning or where there is high humidity in the room causing corrosion – rust, oxidation.

KD door frames can be fitted with a lead coating for radiation protection.



Metal KD door frames have been tested at the Slovenian National Building and Civil Engineering Institute in Ljubljana:

CHARACTERISTIC/PROPERTY	VERIFICATION/TESTING METHOD
Tensile strength	SIST EN 10130
Yield limit	SIST EN 10130
Corrosion resistance	SIST EN ISO 12944

Metal KD door frame advantages:

- They are manufactured on superior hardware (CNC), which ensures precise manufacture and consequently the quality of the product.
- Their corrosion protection is at a high level, which also contributes to their damage resistance.
- The mounting of KD door frames is simple and fast.
- They facilitate smooth closing of the door and a perfect fit of the leaf to the seal.

### SLOVENIAN TECHNICAL APPROVALS AND CERTIFICATES

DESCRIPTION	SLOVENIAN TECHNICAL APPROVALS	CERTIFICATES
KD/SM, KD/MM, KD/SR	STS-09/0061	/

KD door frames can be installed in different walls.

	CONCRETE WALL		GYPSUM BOARD WALL
	MASONRY WALL		METAL CONSTRUCTION
	AERATED CONCRETE		SANDWICH PANEL
	WOODEN WALL		

## DETERMINING OPENING DIRECTION

The opening direction is determined by the space where a particular door frame will be installed. It is important that the door facilitates the passage of people as much as possible and does not impede entering or exiting.

For single-leaf doors – EV:

left (L)



right (R)



For double-leaf doors – DV:

left (L)



right (R)

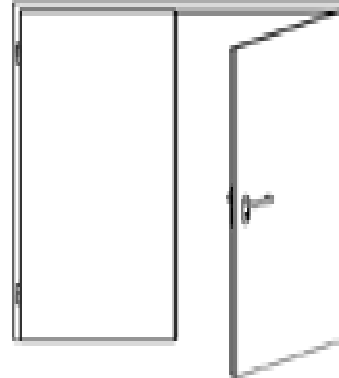

## DOOR FRAME FORMATS

Metal KD door frames are manufactured in the following formats:

basic



fanlight



with a sidelight on one side along the whole height

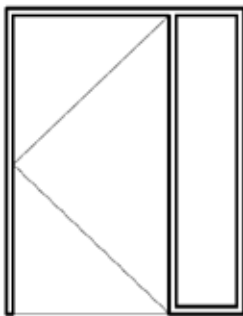

with sidelights on both sides along the whole height

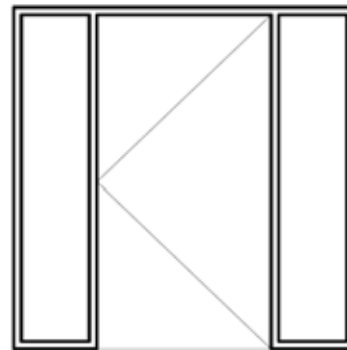

with a fanlight and with a sidelight on one side along the whole height

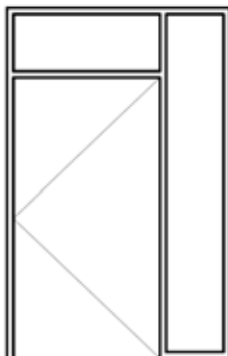

with a fanlight and with sidelights on both sides along the whole height

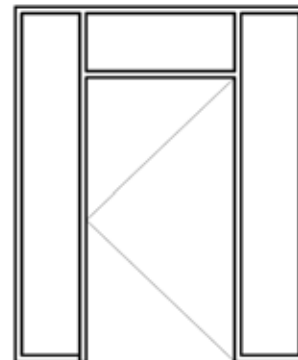



with a fanlight along the whole width and a  
sidelight up to the height of the door on  
one side

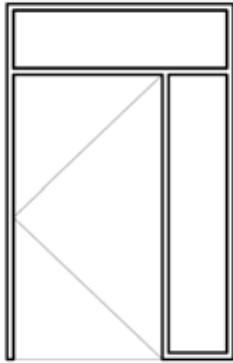

with a fanlight along the whole width and  
sidelights up to the height of the door on  
both sides

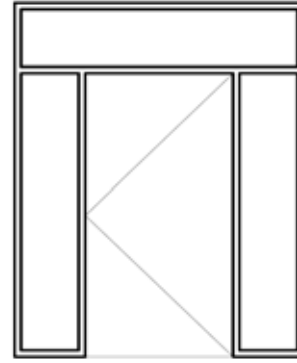

with a fanlight and a side light on one side,  
divided along the height

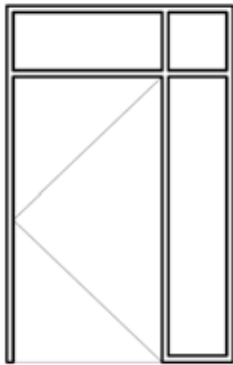

with a fanlight and side lights on both sides,  
divided along the height

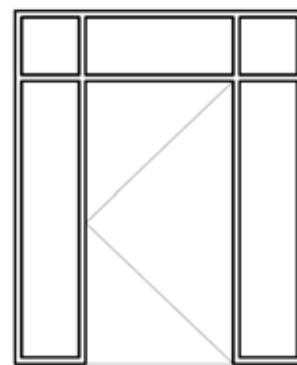

at an angle



for guide rail



## DETERMINING DIMENSIONS

### BASIC DOOR FRAME

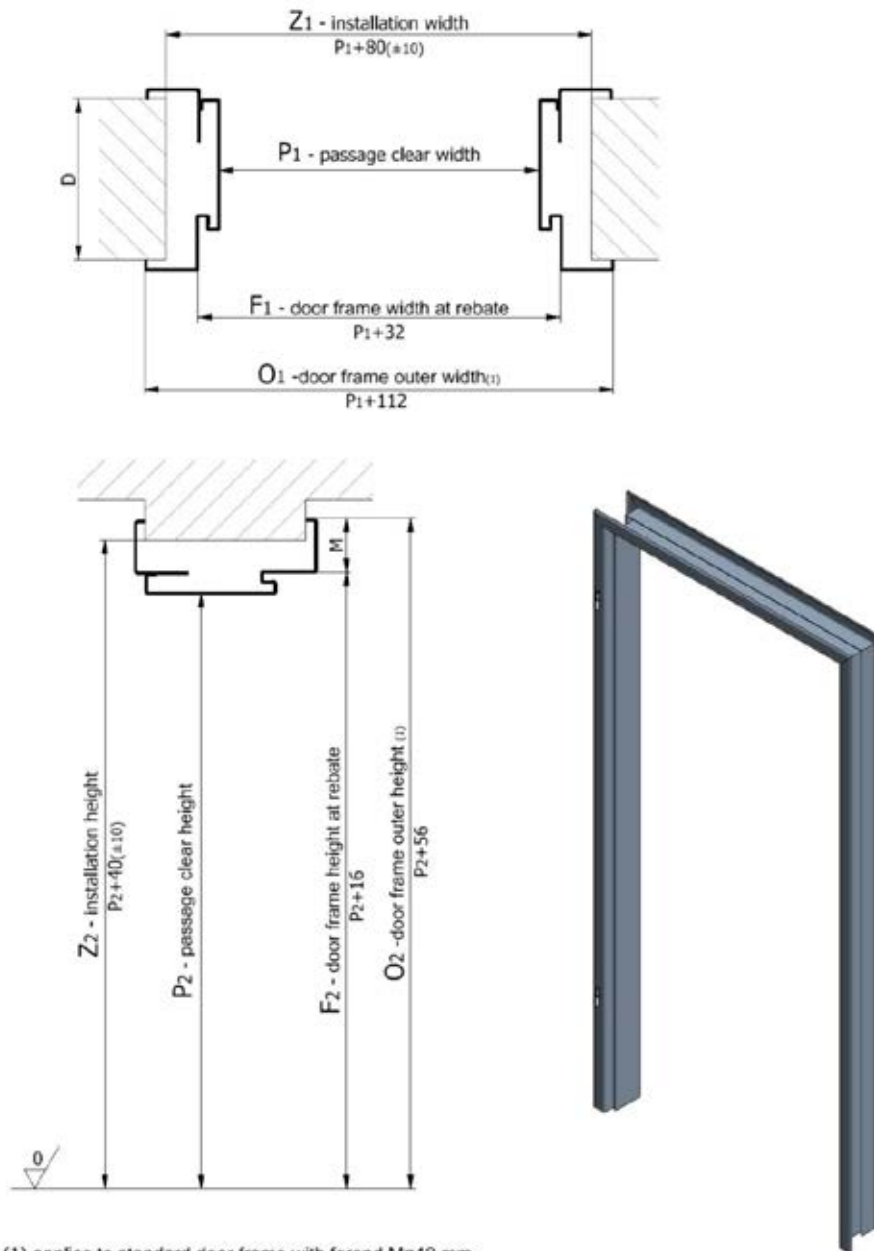

Table with example for calculating door frame dimensions

POSITION	P <sub>1</sub>	F <sub>1</sub>	Z <sub>1</sub>	O <sub>1</sub>	P <sub>2</sub>	F <sub>2</sub>	Z <sub>2</sub>	O <sub>2</sub>	M
FORMULA	/	P <sub>1</sub> +32	P <sub>1</sub> +80	P <sub>1</sub> +112	/	P <sub>2</sub> +16	P <sub>2</sub> +40	P <sub>2</sub> +56	40/50/60
DIMENSION	800	832	880	912	1980	1996	2020	2036	40

## FANLIGHT DOOR FRAME

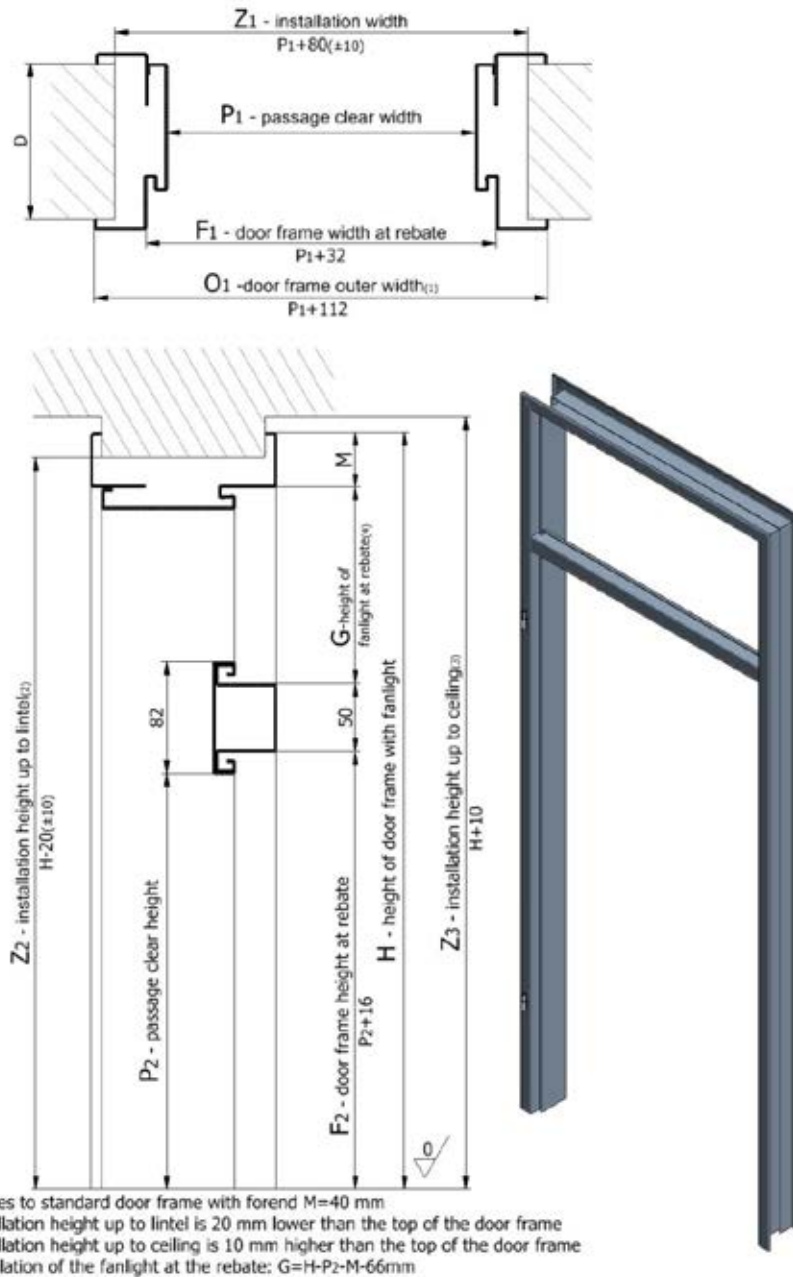
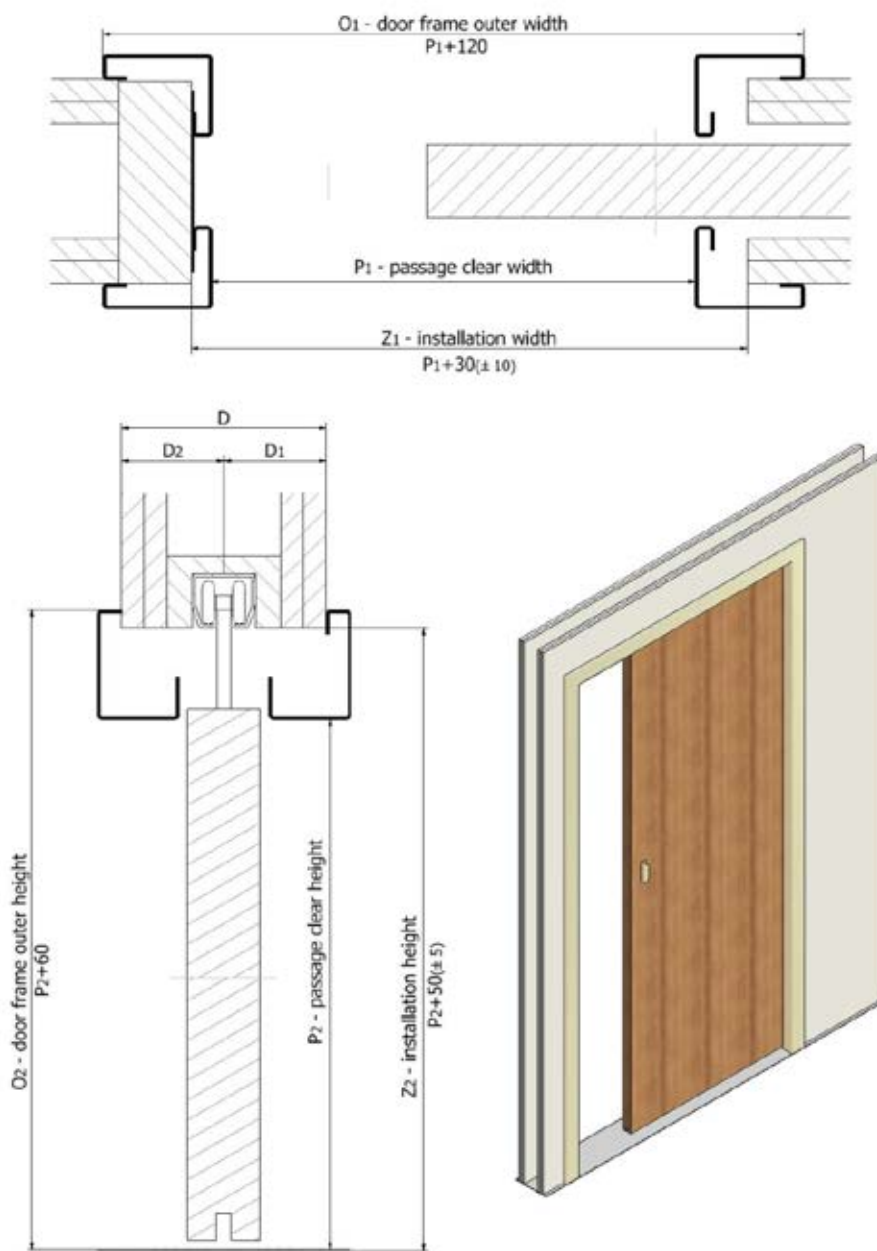

Table with example for calculating dimensions of door frame with fanlight

POSITION	$P_1$	$F_1$	$Z_1$	$O_1$	$P_2$	$F_2$	$Z_2$	H	$Z_3$	G	M
FORMULA	/	$P_1+32$	$P_1+80$	$P_1+112$	/	$P_2+16$	$H-20$	/	$H+10$	$H-P_2-106$	40/50/60
DIMENSION	800	832	880	912	1980	1996	2480	2500	2510	414	40

## KD.OR ORCHIDEA DOOR FRAME



Determining the height and width of the KD.OR door frame

POSITION	$P_1$	$Z_1$	$O_1$	$P_2$	$Z_2$	$O_2$	M
FORMULA	/	$P_1+30$	$P_1+120$	/	$P_2+50$	$P_2+60$	60
DIMENSION (mm)	800	830	920	2000	2050	2060	60



Determining wall thickness

POSITION	T	$T_1$	$T_2$
FORMULA	/	$T = T_1 + T_2$	
DIMENSION (mm)	175	100	75

## DOOR FRAME TYPES

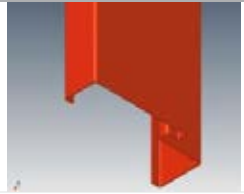
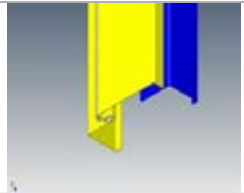
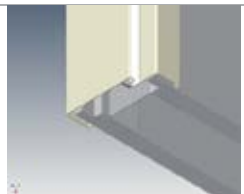

Basic metal door frame types are distinguished by the method of their installation:

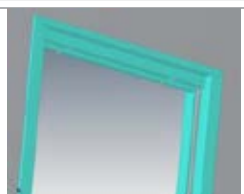
	<ul style="list-style-type: none"> <li>• <b>Wet construction door frames</b></li> </ul>	<b>KD.MM</b>
	<ul style="list-style-type: none"> <li>• <b>Dry construction door frames</b></li> </ul>	<b>KD.SM</b>
	<ul style="list-style-type: none"> <li>• <b>Knauf door frames</b></li> </ul>	<b>KD.KN</b>
	<ul style="list-style-type: none"> <li>• <b>Central door frames</b></li> </ul>	<b>KD.SR</b>
	<ul style="list-style-type: none"> <li>• <b>Orchidea door frames</b></li> </ul>	<b>KD.OR</b>

## KD.MM

The wet construction metal door frame is a single-piece door frame with a groove for a seal.



### STANDARD EQUIPMENT:

- subconstruction for hinge,
- cut-out section for lock striking plateštene,
- anchors for gripping a concrete or masonry wall.

### PROTECTION:

- primer powder coating.

### INSTALLATION:



### SPECIAL FEATURE:

For easier and simpler installation, the KD.MM door frame is extended by 30 mm at the bottom and connected to the door angles.

The door frames have a 0 marking for a precise determination of the height while setting up.

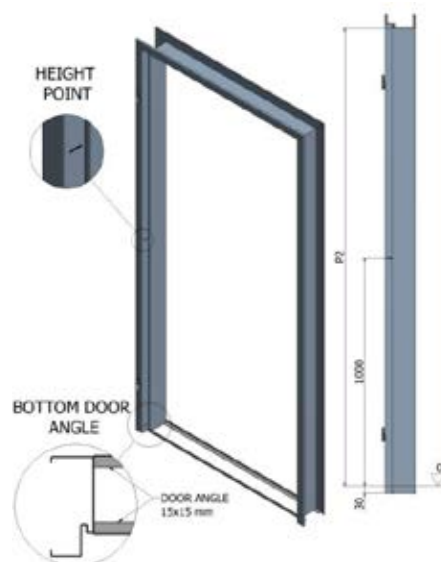

### BASIC MODEL – 1 0

Model:	KD	MM	1	0	30
Description:	door frame for rebated leaf				

Model:	KD	MM	1	0	48
Description:	door frame for non-rebated leaf				

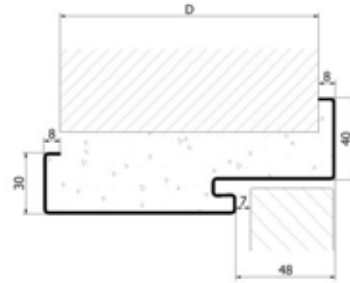
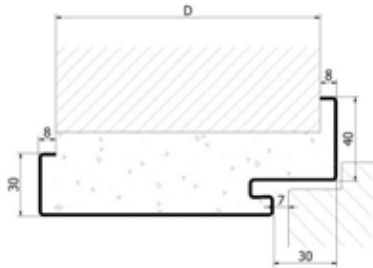

Adaptability to wall thickness:

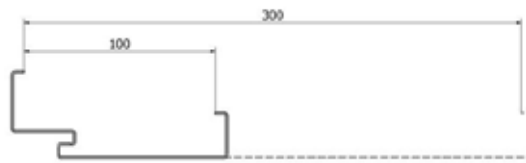

Standard dimension KD.MM 1 0						
D (mm)	100	120	145	160	230	300

### BASIC MODEL – 1 1

Model:	KD	MM	1	1	30
Description:	door frame for rebated leaf				

Model:	KD	MM	1	1	48
Description:	door frame for non-rebated leaf				

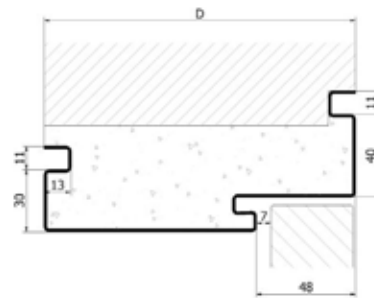
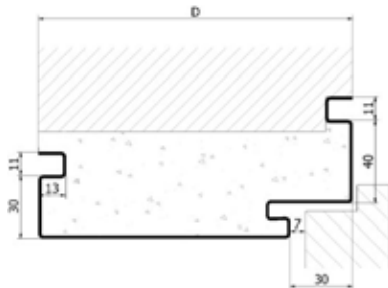

Adaptability to wall thickness:



Standard dimension KD.MM 1 1						
D (mm)	100	120	145	160	230	300

## KD.SM

The **drywall construction metal door frame** is a two-part door frame consisting of a basic and a stop frame. The door frame has a groove for a seal.



KD SM is the most universal door frame suitable for installation in all wall types. It is installed when the walls are already painted and on finished floors. Its basic version is fixed in the opening with polyurethane foam.

The door frame is highly customisable for different wall thicknesses since the stop profile can be configured within  $- 0$  mm and  $+ 25$  mm from the basic dimension of the door frame. They can be equipped with holes for bolting, but cover caps are visible in those places (see page 40).

STANDARD EQUIPMENT (see page 34):

- subconstruction for hinge,
- cut-out section for lock striking plate,
- wedges for fitting the stop frame.

PROTECTION:





- powder coating with a colour from the RAL colour chart

INSTALLATION:



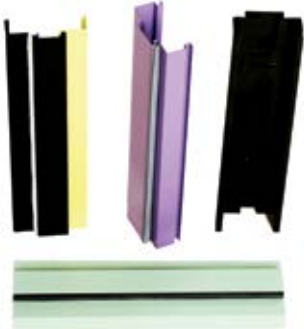

## KD.SM DOOR FRAME SPECIFIC FEATURES

<p><b>KD.SM 1 0</b> <b>KD.SM 1 1</b></p>		<p>The door frame has a groove for a seal. It is suitable for all types of leaves (metal, wood ...). Its dimensions can be adjusted along its height, width, and with regards to the thickness of the wall.</p>
<p><b>KD.SM 2 0</b> <b>KD.SM 2 1</b></p>		<p>The subconstruction of the door frame is adapted for bolting into the wall. When it is assembled together with the stop profile, the bolts are concealed. Because of the strong subconstruction for bolting, the door frame can be filled with stone wool which helps achieve better thermal and sound insulation.</p>
<p><b>KD.SM 3 0</b> <b>KD.SM 3 1</b></p>		<p>The door frame does not have a groove for a seal, so it is suitable for the protection of openings in passages or for combining with sliding doors that are mounted on a wall.</p>
<p><b>KD.SM 4 0</b> <b>KD.SM 4 1</b></p>		<p>The door frame is suitable for installation in walls thicker than 300 mm which you do not wish to cover completely. The rear part of the door frame is not finalised and needs to be finalised with a gypsum board panel or decorative mask, which can be manufactured from various materials, e.g. metal, wood, stone, ceramics, etc.</p>
<p><b>KD.SM 5 0</b></p>		<p>The extension for KD.SM door frames is suitable for use with walls of a greater thickness, from 350 mm onwards. It can be upgraded with a greater number of segments. It is always finalised with a stop profile.</p>

### BASIC MODEL – 1 0

Model:	KD	SM	1	0	30
Description:	door frame for rebated leaf				

Model:	KD	SM	1	0	48
Description:	door frame for non-rebated leaf				

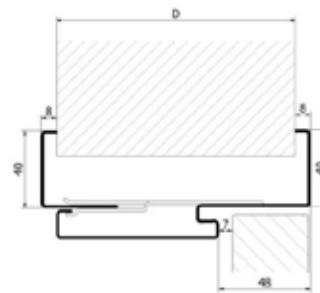
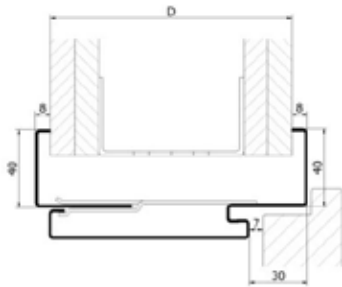

Adaptability to wall thickness:

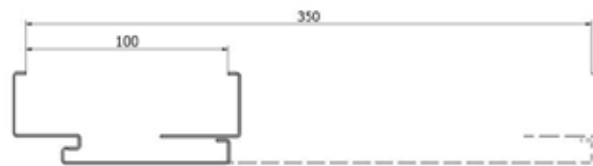

KD.SM 1 0 standard dimensions												
D (mm)	od do	100	125	150	175	200	225	250	275	300	325	350
		124	149	174	199	224	249	274	299	324	349	375
SIDE VIEW		100	125	150	175	200	225	250	275	300	325	350

### BASIC MODEL – 1 1

Model:	KD	SM	1	1	30
Description:	tunnel door frame for rebated leaf				

Model:	KD	SM	1	1	48
Description:	tunnel door frame for non-rebated leaf				

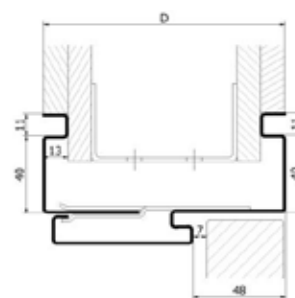
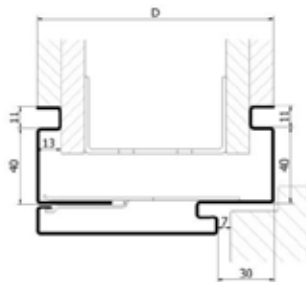

Adaptability to wall thickness:

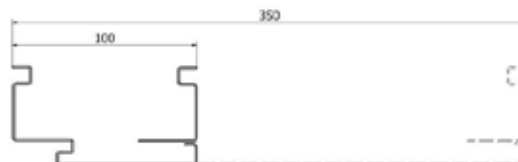

KD.SM 1 1 standard dimensions												
D (mm)	od do	100	125	150	175	200	225	250	275	300	325	350
		124	149	174	199	224	249	274	299	324	349	375
SIDE VIEW		100	125	150	175	200	225	250	275	300	325	350

### MODEL WITH HIDDEN BOLTS – 2 0

Model:	KD	SM	2	0	30
Description:	door frame for rebated leaf				

Model:	KD	SM	2	0	48
Description:	door frame for non-rebated leaf				

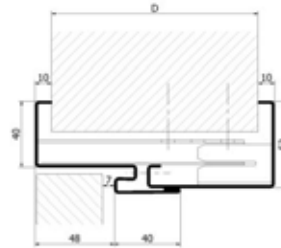
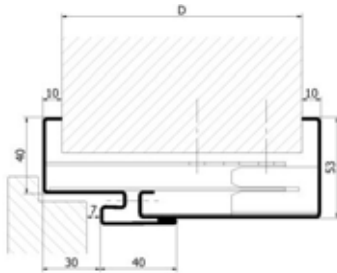

Adaptability to wall thickness:



KD.SM 2 0 standard dimensions												
D (mm)	od	100	125	150	175	200	225	250	275	300	325	350
	do	124	149	174	199	224	249	274	299	324	349	375
SIDE VIEW		100	125	150	175	200	225	250	275	300	325	350

### MODEL WITH HIDDEN BOLTS – 2 1

Model:	KD	SM	2	1	30
Description:	tunnel door frame for rebated leaf				

Model:	KD	SM	2	1	48
Description:	tunnel door frame for non-rebated leaf				

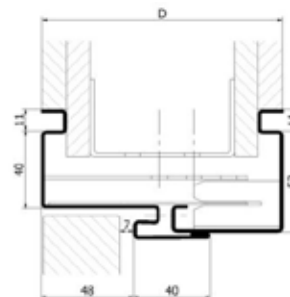
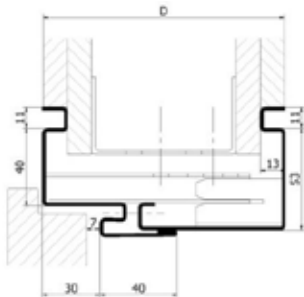

Adaptability to wall thickness:

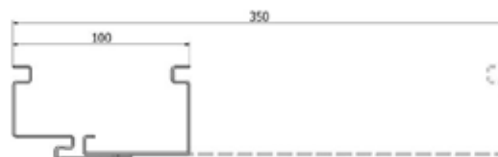

KD.SM 2 1 standard dimensions												
D (mm)	od	100	125	150	175	200	225	250	275	300	325	350
	do	124	149	174	199	224	249	274	299	324	349	375
SIDE VIEW		100	125	150	175	200	225	250	275	300	325	350

### NON-REBATED MODEL – 3 0

Model:	KD	SM	3		0	/
Description:	door frame without a groove for a seal					

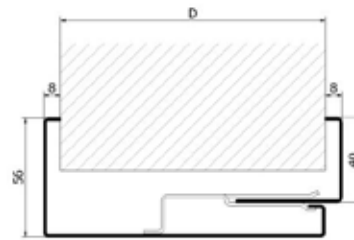

Adaptability to wall thickness:

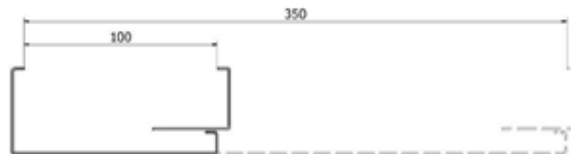

KD.SM 3 0 standard dimensions

D (mm)	od do	100	125	150	175	200	225	250	275	300	325	350
SIDE VIEW		100	125	150	175	200	225	250	275	300	325	350

### NON-REBATED MODEL – 3 1

Model:	KD	SM	3	1	/
Description:	door frame without a groove for a seal				

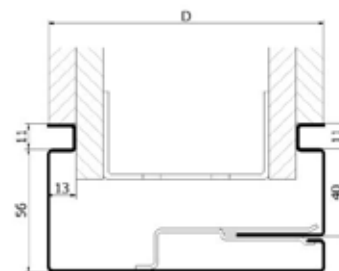

Adaptability to wall thickness:

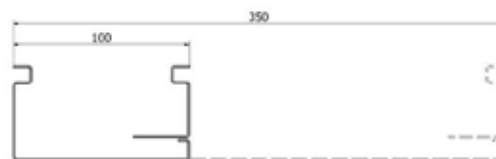

KD.SM 3 1 standard dimensions

D (mm)	od do	100	125	150	175	200	225	250	275	300	325	350
SIDE VIEW		100	125	150	175	200	225	250	275	300	325	350

### CORNER MODEL – 4 0

Model:	KD	SM	4	0	30
Description:	door frame for rebated leaf				

Model:	KD	SM	4	0	48
Description:	door frame for non-rebated leaf				

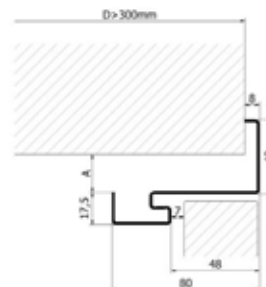
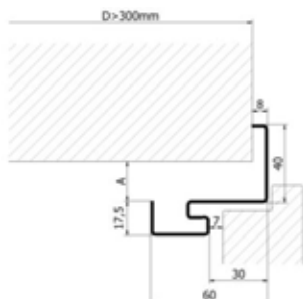

Adaptability to wall thickness:

There is no option for an increase along the thickness of the wall.

### CORNER MODEL – 4 1

Model:	KD	SM	4	1	30
Description:	tunnel door frame for rebated leaf				

Model:	KD	SM	4	1	48
Description:	tunnel door frame for non-rebated leaf				

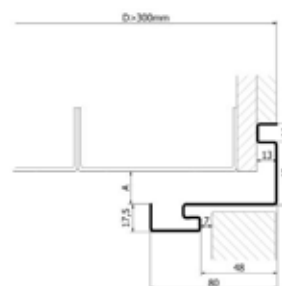
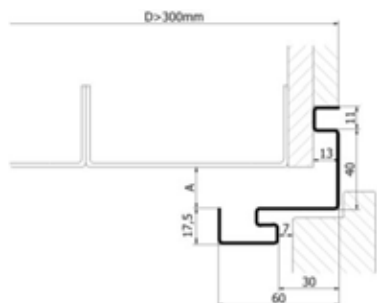

Adaptability to wall thickness:

There is no option for an increase along the thickness of the wall.

## EXTENSION OF DRYWALL DOOR FRAMES – 5 0

Model:	KD	SM	5	0	/
Description:	SM door frame extension for walls of a greater thickness				



Installation example:

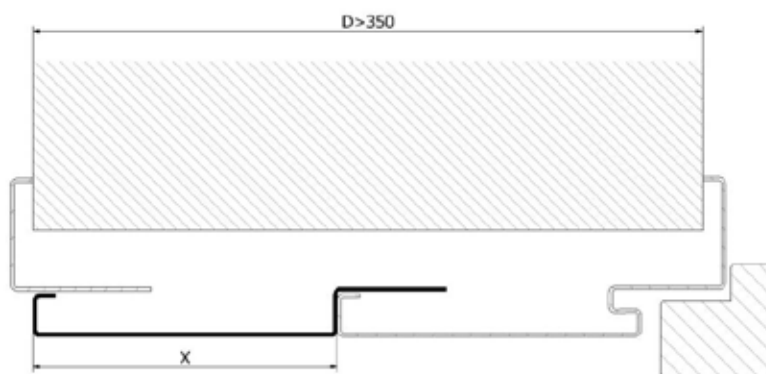

Dimension  $x$  is determined by the selected basic door frame model and the thickness of the wall.

KD SM 5 0 / can be combined with the following models:

- KD SM 1 0 30 or 48 – basic model for rebated or non-rebated leaf
- KD SM 1 1 30 or 48 – basic tunnel model for rebated or non-rebated leaf
- KD SM 3 0 / – non-rebated model without groove for seal
- KD SM 3 1 / – non-rebated tunnel model without groove for seal

## KD.KN

The door frame for gypsum board walls can be single-piece or two-part. Both versions have a groove for sealing rubber. The important difference is in the door frame installation method. The single-piece door frame is mounted in conjunction with the construction of the gypsum board wall. The two-part door frame is mounted in an already existing opening in the gypsum board wall.





STANDARD EQUIPMENT (see page 34):

- sealing rubber,
- subconstruction for the hinge,
- cut-out section for lock,
- subconstruction for bolting.

INSTALLATION:

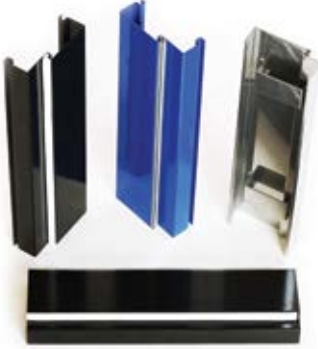

## KD.KN DOOR FRAME SPECIFIC FEATURES

<p><b>KD. KN 1 0</b> <b>KD. KN 1 1</b></p>		<p>The KD KN basic door frame is made from a basic frame. It is equipped with a subconstruction for bolting to the construction of the gypsum board wall. The door frame is mounted in conjunction with the construction of the wall. By agreement, the bottom of the door frame can be extended by 30 mm and connected to the door angles, as well as marked with 0 for an easier determination of the height.</p> <p>PROTECTION: primer powder coating</p>
<p><b>KD.KN 2 0</b> <b>KD.KN 2 1</b></p>		<p>The KD KN door frame with hidden bolts is made from a basic and a stop frame. The basic frame has a subconstruction for bolting in prefabricated walls, and the stop frame has a wedge for fitting to the basic frame. The door frame is mounted in an already existing opening in the gypsum board wall. Because the door frame is in two parts, it can be filled with polyurethane foam or stone wool for better thermal and noise insulation.</p> <p>PROTECTION: powder coating with a colour from the RAL colour chart</p>
<p><b>KD.KN 3 0</b> <b>KD.KN 3 1</b></p>		<p>The KD KN non-rebated door frame is a single-piece door frame made from a basic frame. It is equipped with a subconstruction for bolting to the construction of the gypsum board wall. The door frame is mounted in conjunction with the construction of the wall. By agreement the bottom of the door frame can be extended by 30 mm and connected to the door angles, as well as marked with 0 for an easier determination of the height. The door frame does not have a groove for a seal and is intended for the protection of openings in passages or for combining with sliding doors on walls.</p> <p>PROTECTION: primer powder coating</p>



### BASIC MODEL – 1 0

Model:	KD	KN	1	0	30
Description:	door frame for rebated leaf				

Model:	KD	KN	1	0	48
Description:	door frame for non-rebated leaf				

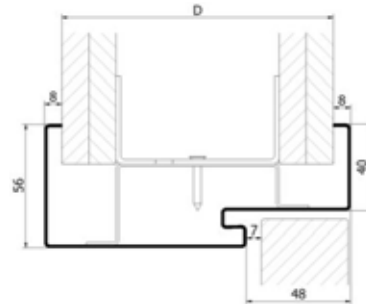
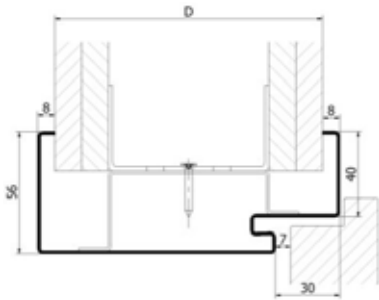

Adaptability to wall thickness:

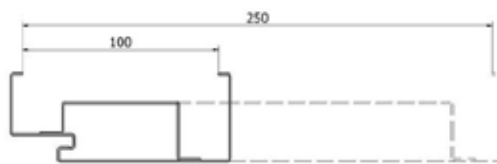

KD.KN 1 0 standard dimensions							
D (mm)	100	125	150	175	200	225	250

### BASIC MODEL – 1 1

Model:	KD	KN	1	1	30
Description:	tunnel door frame for rebated leaf				

Model:	KD	KN	1	1	48
Description:	tunnel door frame for non-rebated leaf				

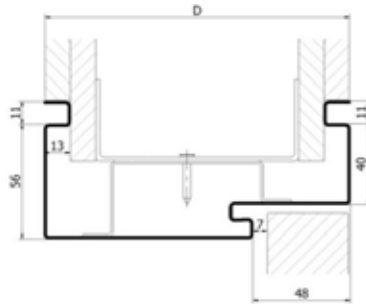
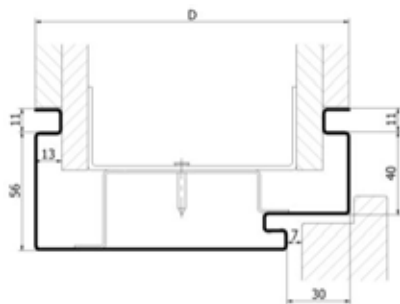

Adaptability to wall thickness:



KD.KN 1 1 standard dimensions							
D (mm)	100	125	150	175	200	225	250

### MODEL WITH HIDDEN BOLTS – 2 0

Model:	KD	KN	2	0	30
Description:	door frame for rebated leaf				

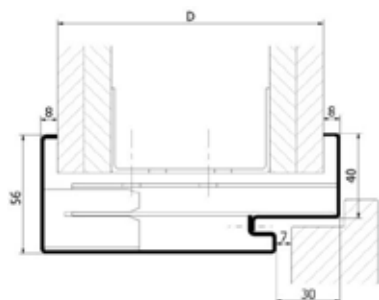

Model:	KD	KN	2	0	48
Description:	door frame for non-rebated leaf				

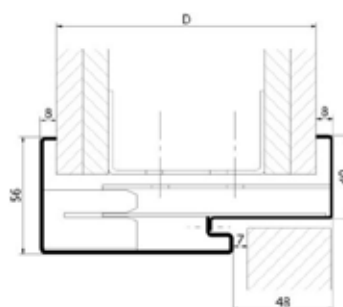

Adaptability to wall thickness:

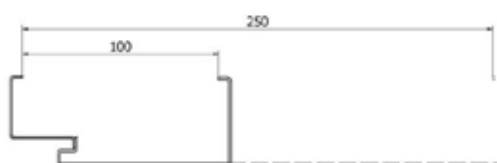

KD.KN 2 0 standard dimensions

D (mm)	100	125	150	175	200	225	250
--------	-----	-----	-----	-----	-----	-----	-----

### MODEL WITH HIDDEN BOLTS – 2 1

Model:	KD	KN	2	1	30
Description:	tunnel door frame for rebated leaf				

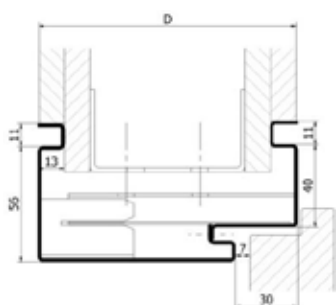

Model:	KD	KN	2	1	48
Description:	tunnel door frame for non-rebated leaf				

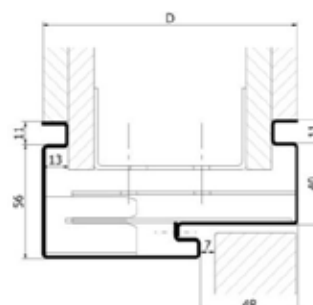

Adaptability to wall thickness:

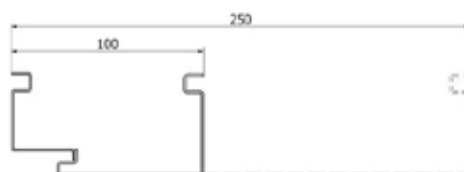

KD.KN 2 1 standard dimensions

D (mm)	100	125	150	175	200	225	250
--------	-----	-----	-----	-----	-----	-----	-----

**NON-REBATED MODEL – 3 0**

Model:	KD	KN	3	0	/
Description:	door frame without a groove for a seal				

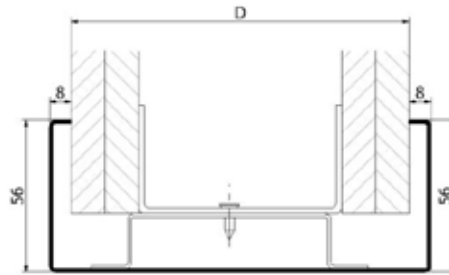

Adaptability to wall thickness:

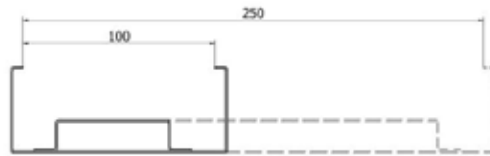

KD.KN 3 0 standard dimensions							
D (mm)	100	125	150	175	200	225	250

**NON-REBATED MODEL – 3 1**

Model:	KD	KN	3	1	/
Description:	door frame without a groove for a seal				

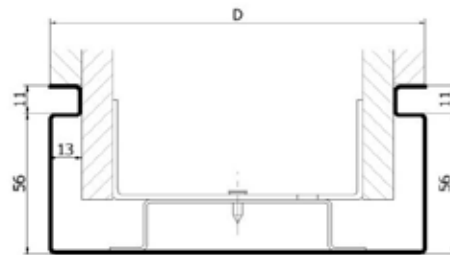

Adaptability to wall thickness:

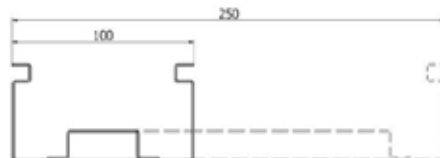

KD.KN 3 1 standard dimensions							
D (mm)	100	125	150	175	200	225	250

## KD.SR

The **central door frame** is a single-piece door frame with a groove for a seal. It is suitable for mounting in corridors or in thicker walls.



### STANDARD EQUIPMENT (see page 37):

- subconstruction for hinge,
- cut-out section for lock striking plate,
- subconstruction for bolting in wall.

### PROTECTION:

- powder coating with colour from the RAL colour chart

### INSTALLATION:



### BASIC MODEL – 1 0

Model:	KD	SR	1	0	30
Description:	door frame for rebated leaf				

Model:	KD	SR	1	0	48
Description:	door frame for non-rebated leaf				

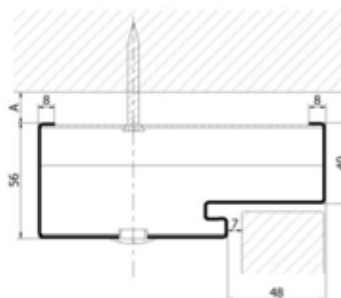
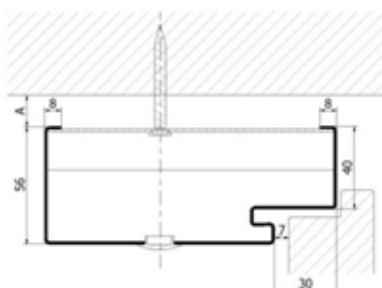

Adaptability to wall thickness:



KD.SR 1 0 standard dimensions			
D (mm)	100	120	150

### BASIC MODEL – 1 1

Model:	KD	SR	1	1	30
Description:	tunnel door frame for rebated leaf				

Model:	KD	SR	1	1	48
Description:	tunnel door frame for non-rebated leaf				

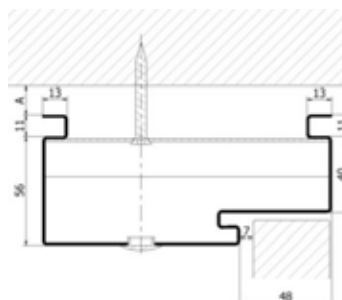
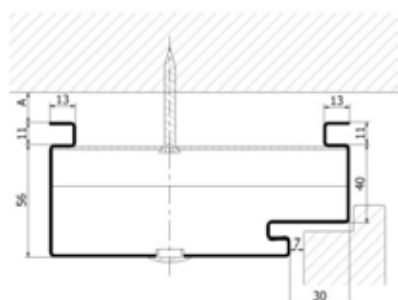

Adaptability to wall thickness:



KD.SR 1 1 standard dimensions			
D (mm)	100	120	150

## KD.OR

The orchidea door frame consists of three parts: a flat metal sheet for closing the front wall and two frames.

One frame is assemblable at the upper transom for easier mounting and setting up of the leaf. Standard subconstructions or pocket frames which can be found on the market are used for installation in the wall.



STANDARD EQUIPMENT:

/

PROTECTION:

- powder coating with a colour from the RAL colour chart

INSTALLATION:



**BASIC MODEL – 1 0**

Model:	KD	OR	1	0	/
Description:	door frame without a groove for a seal				

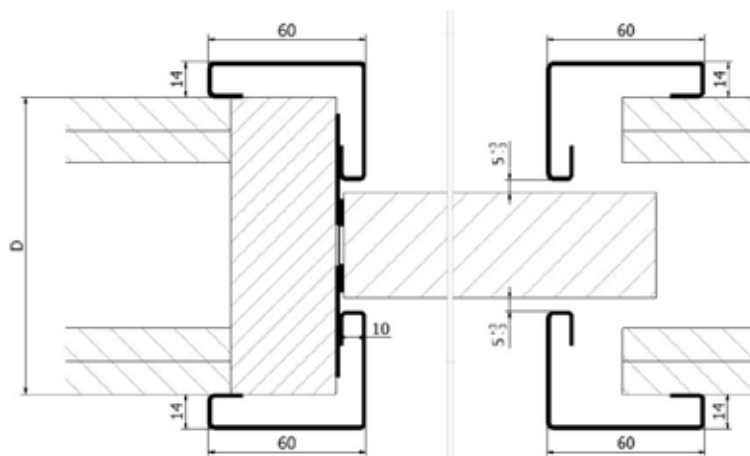

**BASIC MODEL – 1 1**

Model:	KD	OR	1	1	/
Description:	door frame without a groove for a seal				

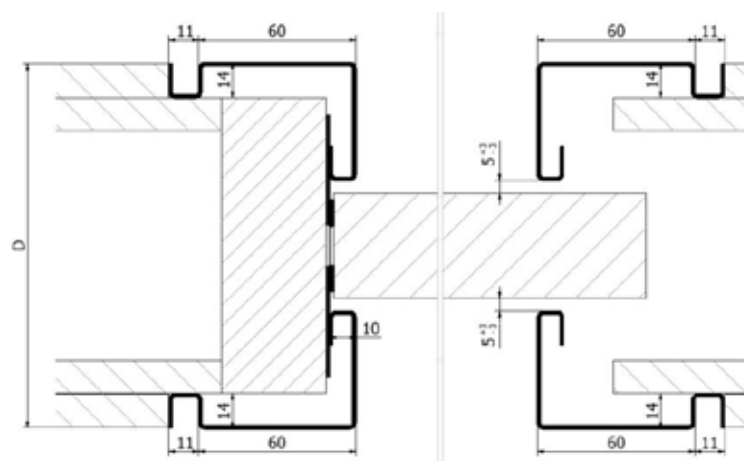

## TRANSOMS FOR FANLIGHTS AND SIDELIGHTS

Transoms for fanlights and sidelights can be used in combination with all door frame models. The depth of the rebate on the transom is determined by the selected door frame model.

Transoms can be used for manufacturing a freestanding wall.

### PR 1

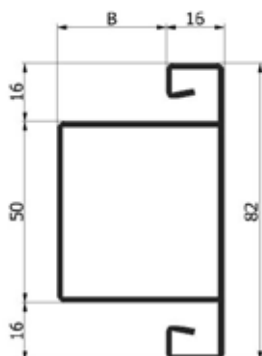

The PR 1 transom is suitable for manufacturing fanlight door frames of any model. The transom can be used in a single or double-leaf door frame.

### PR 2

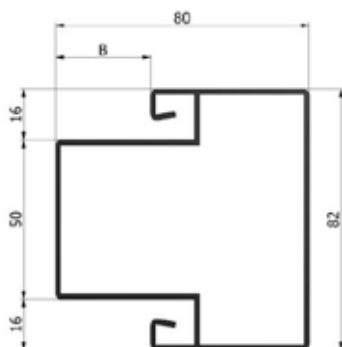

The PR 2 transom is suitable for manufacturing sidelight and fanlight door frames of any model. The transom can be used in a single or double-leaf door frame.

For a composition example see pages 9–10.

### PR 3

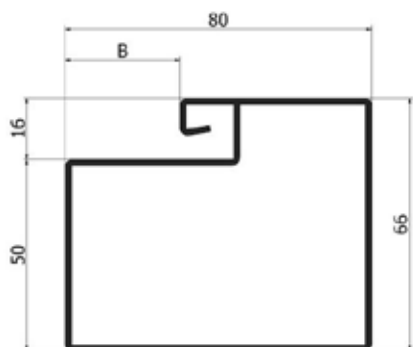

The PR 3 transom is used in combination with the PR 2 transom in the manufacture of a freestanding wall. It is used on the outer side.



## INSTALLATION OF GLASS WITH STANDARD FRAME FOR FANLIGHT

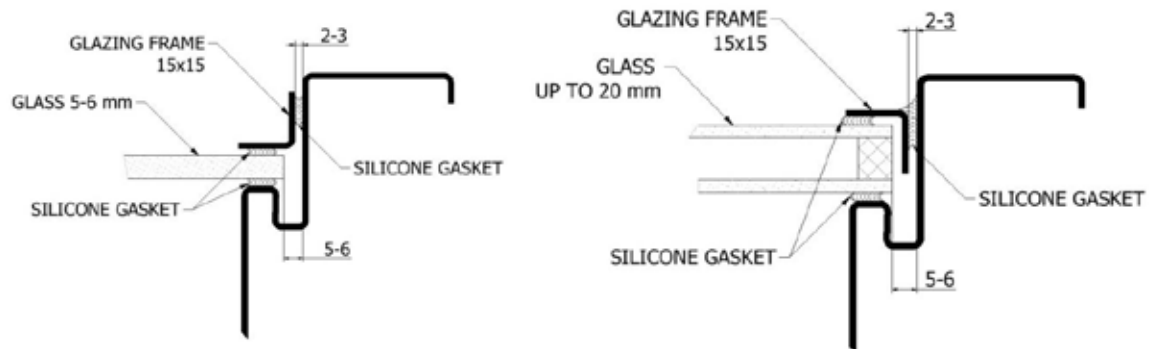

## INSTALLATION OF GLASS FOR SIDELIGHT AND FANLIGHT

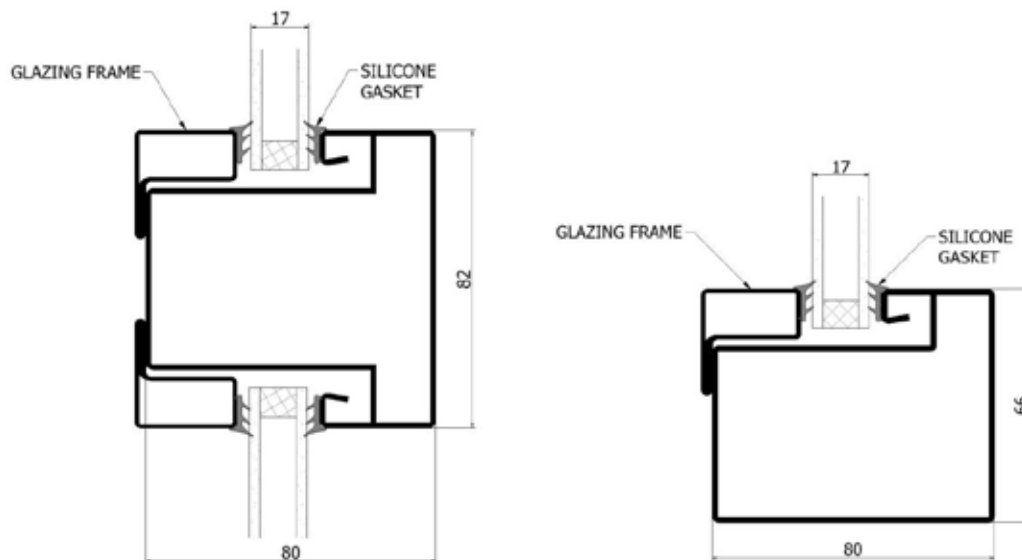

## DOOR FRAME EQUIPMENT

### HINGES

#### HEIGHT OF HINGES

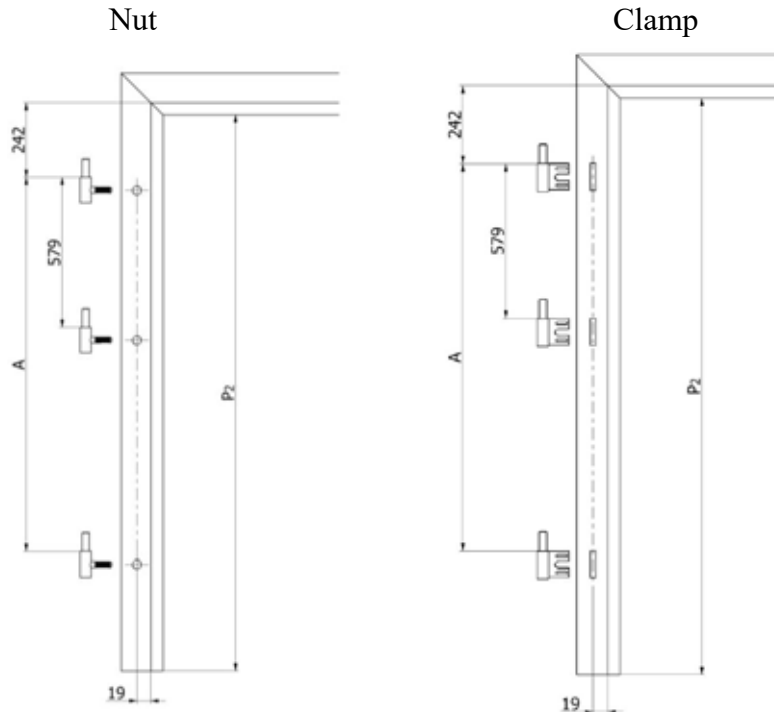





The standard metal KD door frame has two hinges. At the customer's request, a third hinge can be added and installed between the top and bottom hinges. The height of the hinges is measured downwards from the upper transom. Therefore, the top hinge is always considered to be at the same height. The height of the bottom hinge is adjusted based on the  $P_2$  clear height of the door frame. The additional third hinge is always considered to be at the same height, with respect to the top hinge.

$P_2$ (mm)	A
1980–2080	1435
2081–2180	1535
2181–2280	1635

### SUBCONSTRUCTIONS FOR HINGES

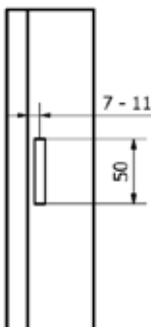
model no.	figure	subconstruction for hinge	examples of corresponding hinges	carrying capacity (leaf mass)
1		Subconstruction with nut M10x1 	hinge Ø15 with thread M10x1	
2		Subconstruction with clamp 	Simonswerk V 8100 WF Simonswerk V 8000 WF OTLAV 102 OTLAV 335	
3		Subconstruction with double nut M10x1 	SFS INTEC	to 120 kg

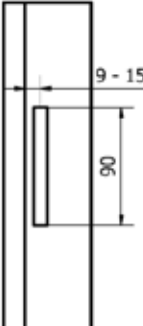
model no.	figure	subconstruction for hinge	examples of corresponding hinges	carrying capacity (leaf mass)
4		Subconstruction Simonswerk V 3610  	Simonswerk V 3400 WF	
			Simonswerk V 4400 WF	
			OTLAV 495	
5		Subconstruction Simonswerk V 7502 3D  	Simonswerk V 7888 WF	to 70 kg
6		Subconstruction Simonswerk V 7611 3D  	Simonswerk VX 7939/120	to 120 kg
			Simonswerk VX 7939/160 Planum	to 160 kg
			Simonswerk VX 7728/120	to 100 kg
			Simonswerk VX 7729/160 Planum	to 160 kg
			VLX-1001-120	to 120 kg
			VLX-1309-120	to 120 kg
			FHX-7939-160 – with spring – self-closing	to 80 kg

model no.	figure	subconstruction for hinge	examples of corresponding hinges	carrying capacity (leaf mass)
7		Subconstruction for hinge Simonswerk VN 2927 	Simonswerk VN 2927/120 Compact	to 120 kg
			Simonswerk VN 2927/160 Compact Planum	to 160 kg
8		Subconstruction for hidden hinge 	PIVOTA DX 38-3D	to 40 kg
			PIVOTA DX 61-3D	to 60 kg
			PIVOTA DX 101-3D	to 100 kg
			Simonswerk TECTUS 240 3D	to 40 kg
			Simonswerk TECTUS 340 3D	to 80 kg
			Simonswerk TECTUS 340 3D FR	to 80 kg

## STRIKING PLATES

### HEIGHT OF STRIKING PLATES

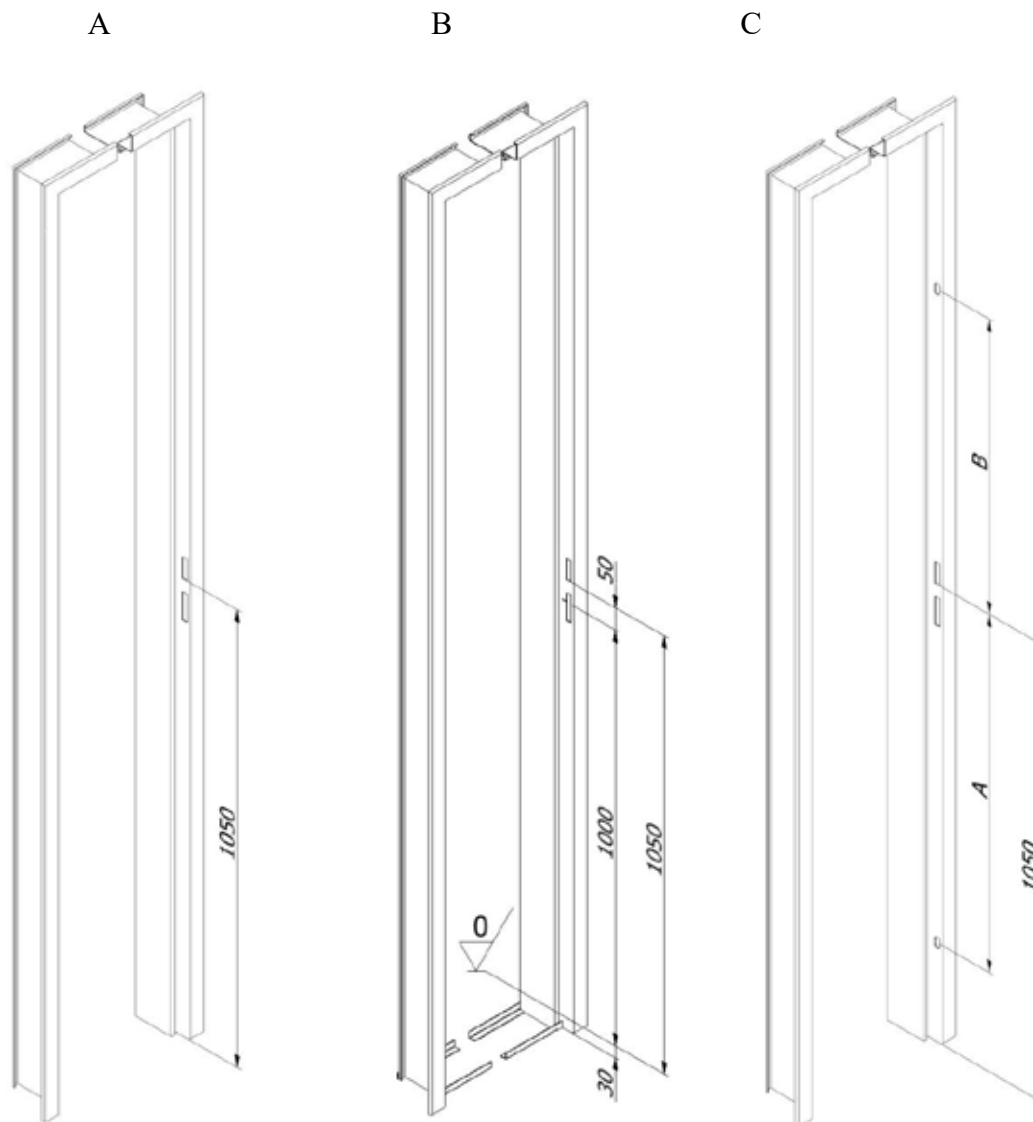





The height of the striking plate for the lock is always measured upwards from the bottom edge of the door frame.

**A** – In the case of door frames that are mounted on finished floors, the cut-out section is at a height of 1050 mm.

**B** – For door frames that are installed in the floor (KD.MM), the height of the striking plate is determined by the height point for the installation of the door frame. The height point is 1000 mm from the finished floor.

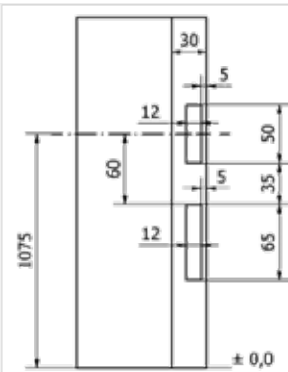
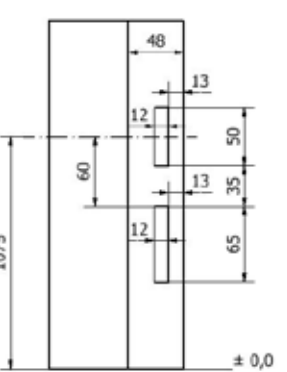
**C** – In the case of door frames which foresee a lock with three latch bolts or more, the dimensions of the cut-out section are adapted to a particular lock.

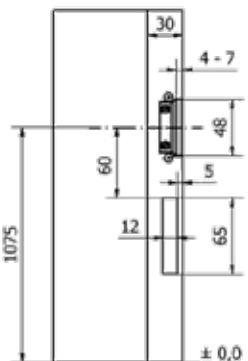
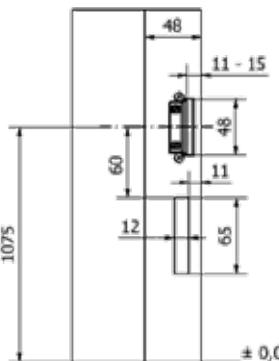
### CUT-OUT SECTIONS FOR STRIKING PLATES

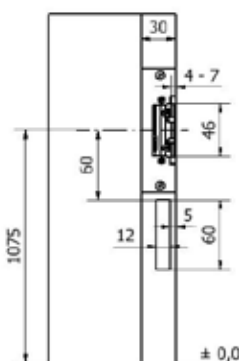
model no.	figure	plan	
1	 <p>Regular cut-out section</p>	<p>For rebated leaf (30 mm)</p> 	<p>For non-rebated leaf (48 mm)</p> 
2	 <p>Cut-out section for adjustable striking plate</p>	<p>For rebated leaf (30 mm)</p> 	<p>For non-rebated leaf (48 mm)</p> 
3	 <p>Electric striking plate eff-eff 118.14 in 118.24</p>	<p>For rebated leaf (30 mm)</p> 	

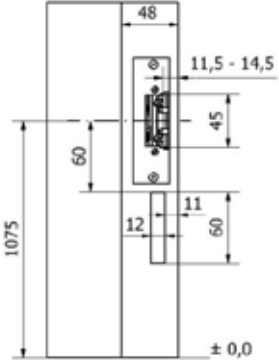
model no.	figure	plan
4		<p style="text-align: center;">For non-rebated leaf (48 mm)</p>  <p style="text-align: center;">Electric striking plate eff-eff 118.13 in 118.23</p>

## HOLES FOR BOLTING

When ordering metal KD door frames, you can choose whether you would like holes for bolting on the door frame:

0 – no holes    1 – holes for bolting

Holes for bolting are inserted on the upright profile. and on the upper transom, based on the clear width of the door frame.

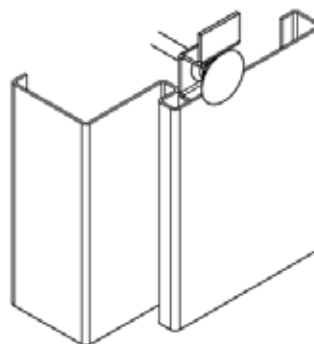
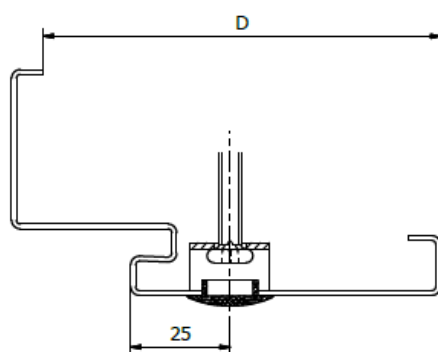

Arrangement of holes based on the thickness of the wall T

thickness of wall T	
less than 200 mm	1 line of holes
from 200 to 350 mm	2 lines of holes

Determining the number of holes for bolting based on the clear width  $P_1$  and clear height  $P_2$

clear width $P_1$ (mm)	no. of holes	clear height $P_2$ (mm)	no. of holes
1000–1600	1	1980–2200	3
1600–2400	2	2200–3000	4
2400–3000	3		



## SPECIAL DOOR FRAMES

### DOOR FRAME WITH DOUBLE SEAL

KD-PP-1-0

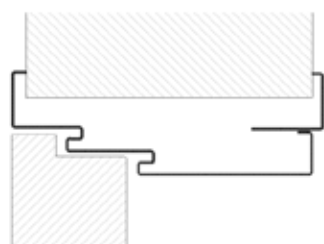

KD-PP-1-1

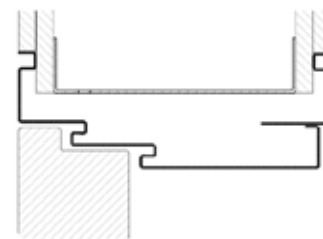

### ROUNDED DOOR FRAME

KD-PP-2-0

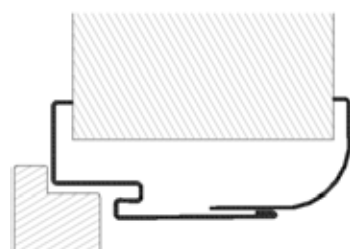

KD-PP-2-1

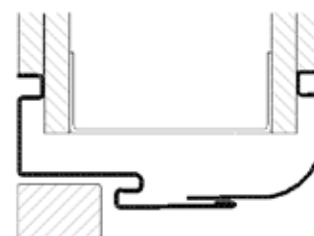

### DOOR FRAME FOR TWO LEAVES

KD-PP-3-0

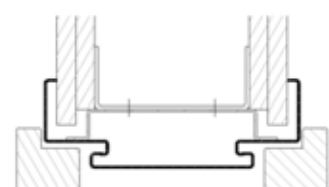

KD-PP-3-1

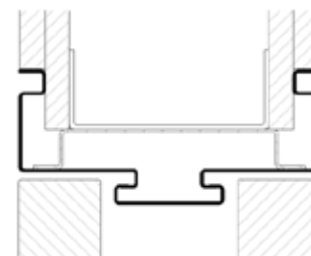

### ASSEMBLABLE DOOR FRAME FOR TWO LEAVES

KD-PP-4-0

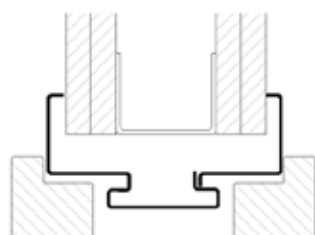

KD-PP-4-1

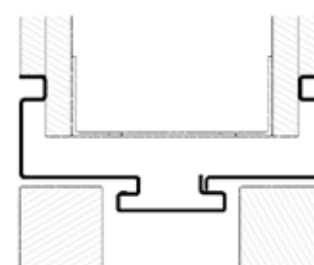

DOOR FRAME UNDER ANGLE

KD-PP-5-0

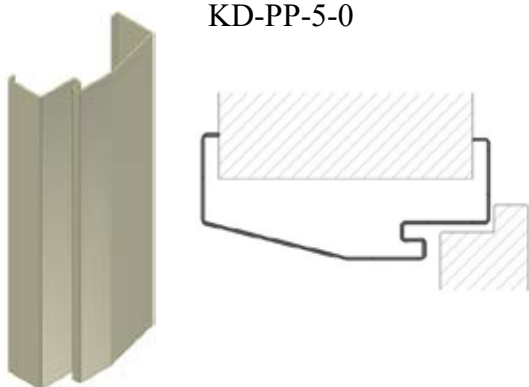

KD-PP-5-1

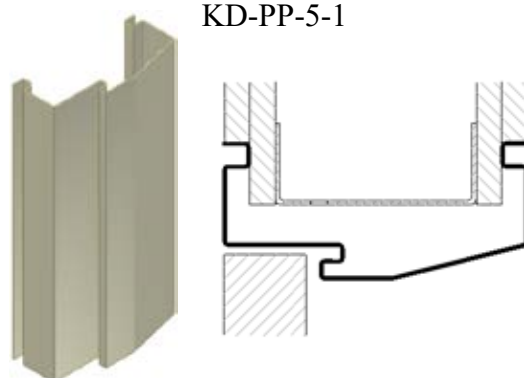

DOOR FRAME FOR SWING DOOR

KD-PP-6-0

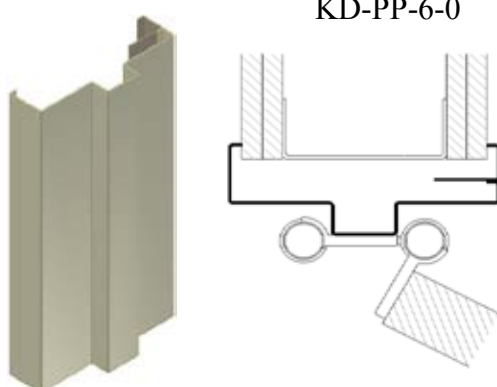

KD-PP-6-1

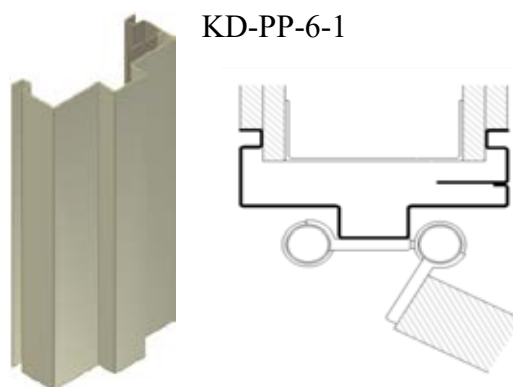

DOOR FRAME FOR GLAZING

KD-PP-7-0

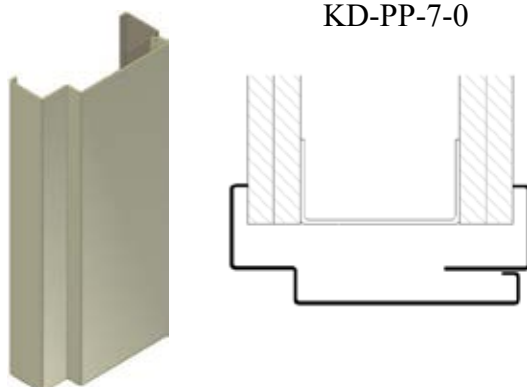

KD-PP-7-1

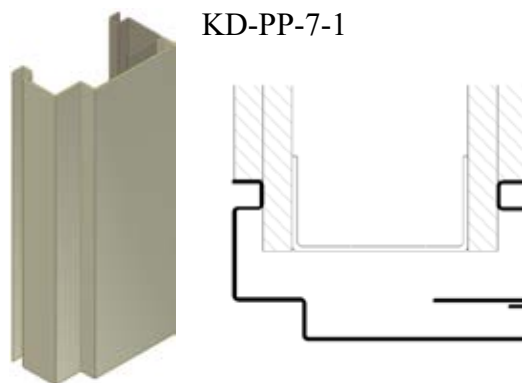

CONTRA DOOR FRAME

KD-PP-8-0

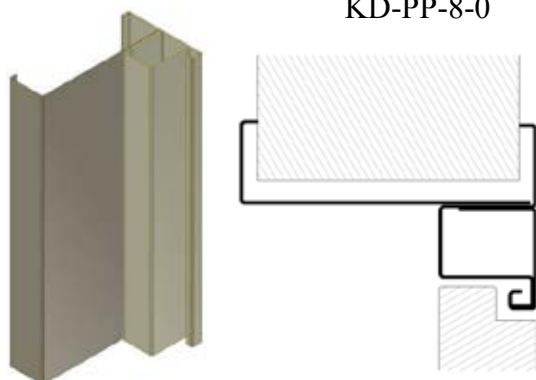

KD-PP-8-1

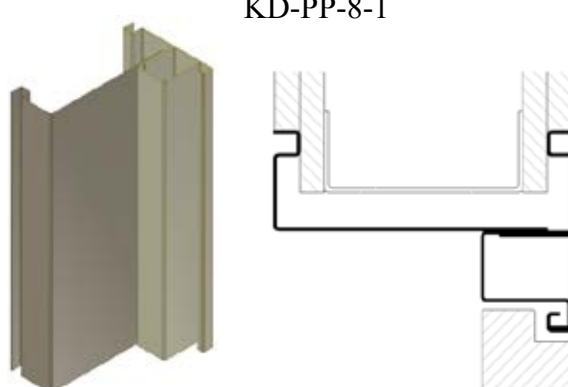

CONCEALED DOOR FRAME

KD-PP-10-0

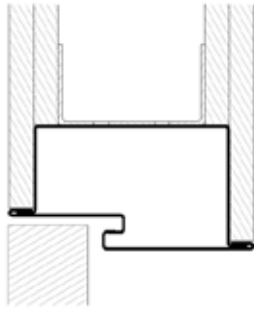

DOOR FRAME FOR THIN WALL

KD-PP-11-0



DOOR FRAME WITH FIRE TAPE

KD-PP-12-0

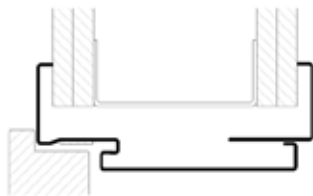

KD-PP-12-1

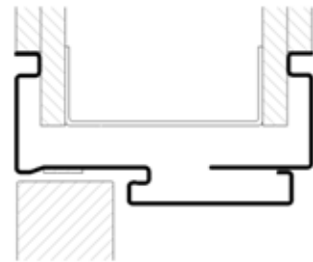

## ORDERING INSTRUCTIONS

When ordering metal KD door frames, the following information is required:

### 1. SELECT DOOR FRAME MODEL

In the catalogue, select a door frame model which suits you and write down its code:

wet construction – KD.MM – p. 14

drywood construction – KD.SM – p. 16

knauf – KD.KN – p. 23

central – KD.SR – p. 28

orchidea door frames – KD.OR – p. 30

### 2. SELECT EQUIPMENT

#### 2.1 SELECT SUBCONSTRUCTION FOR HINGES

The table on pages 35-37 presents all subconstructions for hinges. Select model number.

#### 2.2 SELECT STRIKING PLATE:

The table on pages 38-40 presents all possible striking plates. Select model number.

#### 2.3 SELECT HOLES FOR BOLTING

See page 38.

### 3. DETERMINE DIMENSIONS

Select the thickness of the wall, the width and the height of the opening – see page 10.

In the case of a fanlight door frame, see p. 11.

For orchidea door frames see page 12.

### 4. OPENING DIRECTION

#### 4.1 SELECT SINGLE-LEAF – EV OR DOUBLE-LEAF – DV DOOR FRAME.

See p. 7.

#### 4.2 SELECT OPENING DIRECTION: LEFT (L) OR RIGHT (R).

See p. 7.

Example:

door frame model					-	equipment			-	dimensions – clear passage = P				-	opening direction	
KD	SM	1	0	30		2	2	1		T=150	P <sub>1</sub> =800	P <sub>2</sub> =1980	H= /		EV	L

The presented example is:

#### DOOR FRAME MODEL:

Metal drywall door frame – basic model – with 30 mm rebate

#### EQUIPMENT:

- 2 – welding nut
- 2 – adjustable striking plate
- 1 – holes for bolting

#### DIMENSIONS:

For a wall thickness of T = 150 mm

Clear dimension: width of opening P<sub>1</sub> = 800 mm and height of opening P<sub>2</sub> = 1980 mm

#### OPENING DIRECTION:

Single-leaf, left door frame

Based on your order we will prepare an ORDER CONFIRMATION, which is the basis for creating a work order. Once we receive a signed and stamped confirmation from you, the order will go into production.

All dimensions in the catalog are in millimeters (mm).

We reserve the right to make changes.

**Any copying and publishing of the content without the consent of the company Deržič Vrata, s. p., is prohibited and contrary to the Intellectual Property Act.**

